OVENS

Installation - Use - Maintenance



GENERAL INFORMATION

Please read this booklet thoroughly before you use this appliance. It is important that you understand all the control functions before commencing to cook with your new appliance.

Please remember the advice and warnings shown in this manual which is headed 'IMPORTANT – Warning and Safety Instructions'.

This appliance is designed for domestic household use and can be built into a standard kitchen cabinet or housing unit.

NOTE: The adjacent furniture or the housing and all materials used in the installation must be able to withstand a minimum temperature rise of 85C above ambient during periods of use.

Certain types of vinyl or laminate kitchen furniture are particularly prone to heat damage or discolouration at temperatures below the above guidelines.

Installing the appliance in contravention of this temperature limit or the placing of adjacent cabinet materials closer than 4mm to the appliance, will be at the liability of the owner.

The use for any other purpose or in any other environment without the express agreement of the manufacture or its agent, would invalidate any warranty or liability claim

Your new appliance is guaranteed against electrical or mechanical defects subject to certain exclusions noted in the Conditions of Guarantee.

The foregoing does not affect your statutory rights.

Before using this appliance ensure that any protective packaging or coatings have been removed. To aid the protection of the environment, please sort the packing materials into different types and dispose of them in accordance with the local waste disposal laws.

Any further information on waste disposal can be obtained from your local Environmental Agency office.

When first used, an odour may be emitted by any residual protective finish or moisture, which will cease after a short period of time.

This Appliance has been Constructed and Distributed in compliance with the essential requirements of the following EEC DIRECTIVES and EUROPEAN NORMS:-

CE Marking – 93/68 Low Voltage – 73/23 EMC – 89/336

Safety Standards – EN 60 335-1, EN 60 335 – 2 – 6, AS/NZS3350-1, AS/NZS3350-2-6

As we have a policy of continued product improvement, the right is reserved to adjust and make any modifications deemed necessary without notification.

IMPORTANT NOTE – WARNING and SAFETY INSTRUCTIONS

This appliance complies with all current safety legislation, however the manufacture wishes to emphasise that compliance does not remove the fact that the appliance surfaces will become hot during use and retain heat after operation.

We advise that the appliance is not intended for use by young children and infirm persons without supervision. Young children should be supervised to ensure they do not play with the appliance. If it is necessary for younger family members to be in the kitchen, please ensure that they are kept under close supervision at all times. We also advise that great care is taken during use and cleaning operations.

Do not place heavy objects on or lean on the oven door when open as this can cause damage to the hinging.

Do not leave heated oil or fat unattended as there is a risk of fire.

Do not place pans or baking trays on the bottom of oven cavities or line with Aluminium Foil.

Do not allow electrical fittings or cables to be in contact with hot areas of the appliance.

Do not use the appliance for space heating or to dry clothes.

Do not install the appliance next to curtains or soft furnishings.

Do not attempt to lift or move cooking appliances by pulling on any door or handle as this can cause damage.

Do not use a steam cleaner to clean the oven.

NOTE: This appliance must be correctly installed by a suitably qualified person, strictly in accordance with the manufacturer's instructions.

For electrical installations, NICEIC registration is recommended.

The manufacture & it's agent declines any responsibility for injury or damage to persons or property as a result of improper use or installation of this appliance.

Heat, steam and moisture will be created during use, take care to avoid injury and ensure that the room is adequately ventilated. If prolonged use occurs, additional ventilation may be required – please consult your Qualified Installer if you are in any doubt about the amount required.

WARNING!!!

accessible parts will become hot when in use. To avoid burns and scalds children should be kept away. Care should be taken to avoid touching heating elements inside the oven.

DEAR CUSTOMER,

We thank you and congratulate you on your choice.

This new carefully designed product, manufactured with the highest quality materials, has been carefully tested to satisfy all your cooking demands.

We would therefore request you to read and follow these easy instructions which will allow you to obtain excellent results right from the start.

THE MANUFACTURER

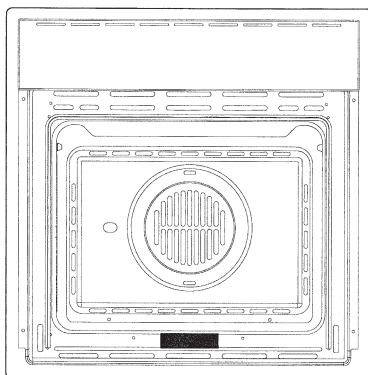

IMPORTANT

The oven's data plate is accessible even with the oven fully installed. The plate is visible simply by opening the door. Always quote the details from it to identify the appliance when ordering spare parts.

CONTENTS

First use	pag. 5
Self-cleaning panel	6
Respect for the environment	6
Control panel	7

Instructions for use:	
- conventional cooking	8
- fan cooking	9
- grill cooking	9
Thermostat	10
Cooking timer	10
Electronic timer	11
Light replacement	12
Removing the oven door	12

INSTALLATION INSTRUCTIONS

Flush fitting	13
Electrical connections	14

THE FIRST TIME YOU USE THE OVEN

Clean the oven thoroughly with soapy water and rinse well. To remove the lateral frames from smooth-walled ovens, proceed as shown in the figure.

Operate the oven for about 30 minutes at maximum temperature to burn off all traces of grease which might otherwise create unpleasant smells when cooking.

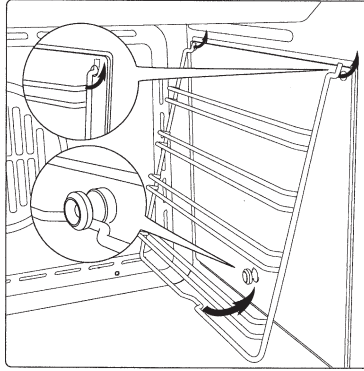

Important:

As a safety precaution, before cleaning the oven, always disconnect the plug from the power socket or the power cable from the oven. Do not use acid or alkaline substances to clean the oven (lemon juice, vinegar, salt, tomatoes etc.). Do not use chlorine based products, acids or abrasive products to clean the painted surfaces of the oven.

PLEASE TILT UP APPROXIMATELY 45 DEGREES TO REMOVE SHELF COMPLETELY

SELF-CLEANING CATALYTIC PANELS

Our smooth walled ovens can be fitted with self-cleaning panels to cover the inside walls.

These special panels are simply hooked on to the walls before the side frames are fitted. They are coated in a special, micro-porous catalytic enamel which oxidises and gradually vaporises splashes of grease and oil at cooking temperatures above 200° C.

If the oven is not clean after cooking fatty foods, operate the empty oven for 60 minutes (max.) at maximum temperature.

Never wash or clean self-cleaning panels with abrasive, acid, or alkaline products.

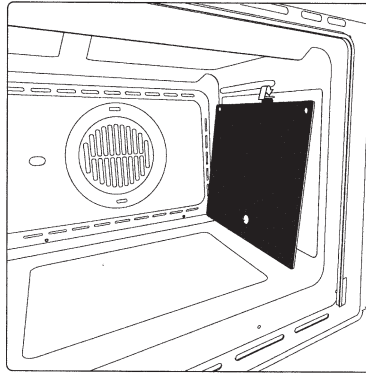

RESPECT FOR THE ENVIRONMENT

The documentation provided with this oven has been printed on chlorine free bleached paper or recycled paper to show respect for the environment.

The packaging has also been designed to avoid environmental impact. Packaging material is ecological and can be re-used or recycled.

By recycling the packaging, you will help save raw materials as well as reducing the bulk of domestic and industrial waste.

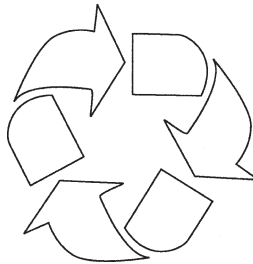

CONTROL PANEL FUNCTIONS

FUNCTION SYMBOLS ON THE SELECTOR



Oven light (stays on while oven is in use).



Bottom heating element.
Thermostat setting from 50°C to MAX.



Top and bottom heating elements. Thermostat setting from 50°C to MAX.



Top and bottom heating elements with fan. Thermostat setting from 50°C to MAX.



Circular heating element with fan. Thermostat setting from 50°C to MAX.



Fan for defrosting. Thermostat setting at 0°C.



Bottom heating element with fan. Thermostat setting from 50°C to MAX.



Double top heating element with fan (large area grill). Thermostat setting from 50°C to 200°C.



Double top heating element (large area grill). Thermostat setting from 50°C to 200°C.



Top heating element (small, low power grill). Thermostat setting from 50°C to 200°C.

INSTRUCTIONS FOR USE

CONVENTIONAL COOKING



Conventional cooking uses top and bottom heat to cook a single dish.

Place the food in the oven only once cooking temperature has been reached, i.e. when the heating indicator goes out.

If you want to increase top or bottom temperature towards the end of the cooking cycle, set the temperature control to the right position. It is advisable to open the oven door as little as possible during cooking.

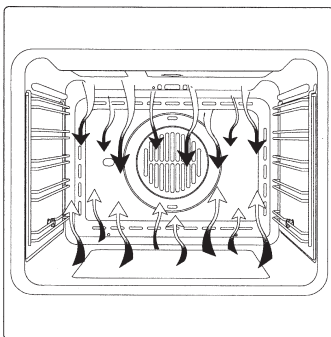

FAN COOKING



For this type of cooking a fan positioned at the back allows the circulation of hot air inside the oven, creating uniform heat. In this way cooking is more rapid than conventional cooking. It is a suitable method for cooking dishes on more than one shelf, especially when the food is of different types (fish, meat etc.)

DEFROSTING



By selecting one of the fan cooking functions and setting the thermostat to zero, the fan allows cold air to circulate inside the oven. In this way frozen food can be rapidly defrosted.

It is not essential to pre-heat the oven, but you are advised to do so when cooking pastries.

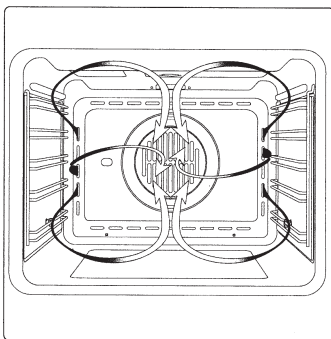

GRILL COOKING



Use the grill to grill or brown foods.

Some ovens may be equipped with an electric motor, spit and skewers for turning on the spit.

Place the shelf with the food to be cooked in the 1st or 2nd position from the top.

Pre-heat the oven for 5 minutes. Turn the thermostat to a temperature between 50° and 200°.

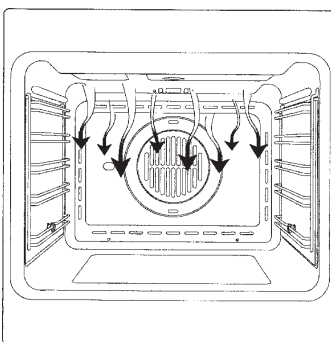

COOLING FAN

The fan is positioned on the upper part of the oven and create a circle of cooling air on the inside of the furniture and through the door of the oven.

It is turned on when the temperature of the outer shell of the oven reaches 60°C.

By switching on the oven with the thermostat at 200°C the fan starts working after approx.10 min.

It is turned off when the temperature of the outer shell of the oven descends under 60°C.

By switching off the oven with the thermostat at 200°C the fan stops working after approx. 30 min.

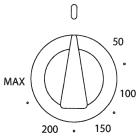

THERMOSTAT

Use the thermostat to set the cooking temperature you need. The thermostat can be adjusted from 50° to 250° C.

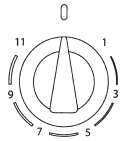

0-11 HEAT REGULATOR

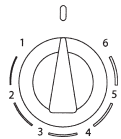

0-6 SELECTOR

Use these to adjust the heat in the cast iron or glass-ceramic plates. Increase the setting from 0 to 6 or from 0 to 11 to raise the temperature.

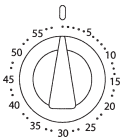

ALARM TIMER

You can set this timer to sound a buzzer after 0 to 60 minutes of cooking. First turn the knob fully clockwise, then turn it back to the desired alarm time.

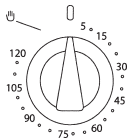

COOKING TIMER

First, turn the cooking selector to the required cooking function, and the thermostat to the desired cooking temperature.

Then, to set *end of cooking time*, turn the cooking timer to the right and to the desired time. First turn the knob fully clockwise, then turn it back to the desired alarm time. A buzzer sounds at the end of the timed cooking period, and the oven switches itself off.

To set the oven to manual operation (not timer), turn the timer anticlockwise to the hand symbol.

PROGRAMMING END OF COOKING TIME WITH THE ANALOGUE TIMER

Setting the clock

Pull the knob out and turn it clockwise to set the clock.

First, turn the cooking selector to the required cooking function, and the thermostat to the desired cooking temperature. Then, to set *end of cooking time*, turn the cooking timer to the right and to the desired time. A buzzer sounds at the end of the timed cooking period, and the oven switches itself off. Push the timer knob in to silence the buzzer .

To set only the *start of cooking*, leave the knob in the manual  position.

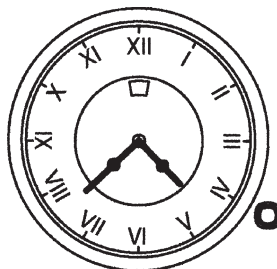

6 KEY ELECTRONIC TIMER



Setting the clock

Press the duration  key and the end of cooking  key simultaneously, then press the +/- keys to set the time.

MANUAL OPERATION

To start cooking without setting *end of cooking time*, press the manual key  .



SETTING ONLY THE DURATION OF COOKING IN SEMI-AUTOMATIC MODE

To set the *duration of cooking*, press the duration key  and press the +/- keys to set the duration of cooking. A buzzer sounds when the cooking period finishes, and the oven switches itself off. Turn the thermostat and selector knobs back to 0 position and press the manual key.

SETTING ONLY THE END OF COOKING TIME IN SEMI-AUTOMATIC MODE

To set the *end of cooking time*, press the end of cooking key  and press the +/- keys to set the time at which you want the oven to switch off. A buzzer sounds when the clock reaches the set time, and the oven switches itself off. Turn the thermostat and selector knobs back to 0 position and press the manual key.

FULLY AUTOMATIC OPERATION

To set the *end of cooking time*, press the duration key  and press the +/- keys to set the duration of cooking. Press the end of cooking key  and press the +/- keys to set the time at which you want the oven to switch off. When you finish setting these times, the AUTO symbol flashes and the buzzer sounds. Press any key to silence it

ALARM TIMER

Press the alarm timer key and press the +/- keys to set the required duration of cooking. The *buzzer* sounds when the cooking time ends. Press any key to silence it.

PROGRAMMING ERRORS

You cannot program in a cooking period which starts earlier than the time displayed on the clock. If you try to do so, the buzzer sounds and the AUTO symbol flashes. Simply change the duration or cooking time to correct the error.

CANCELLING A COOKING PROGRAMME

To cancel a cooking programme, simply press the manual key.

REPLACING THE OVEN LIGHT

IMPORTANT:

The oven light must have these precise features:

- a) it must be able to resist high temperatures (up to 300°C)
- b) power supply: see V/Hz indicated on data plate.
- c) power 25W.
- d) E 14 connection.

Before proceeding, disconnect the appliance from the main electricity supply.

- to prevent damage, place a tea cloth in the oven
- unscrew the glass cover of the light
- unscrew the old light bulb and replace it with the new one
- put back the glass cover and remove the tea cloth
- connect the appliance to the main electricity supply

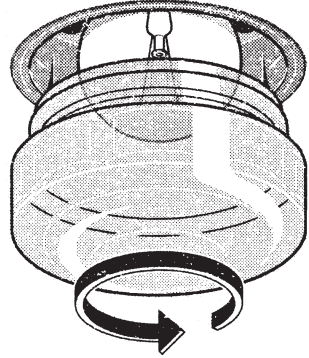

REMOVING THE OVEN DOOR

The oven door can be removed quickly and easily. To do so, proceed as follows:

- Open the door fully.
- Lift the two levers shown in fig.
- Close the door as far as the first stop (caused by the raised levers).
- Lift the door upwards and outwards to remove it from its mountings.

To replace fit the door, fit the hinges in their mountings and lower the two levers.

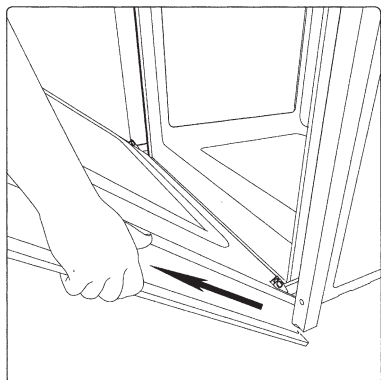
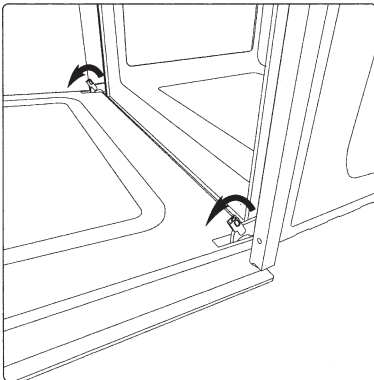

INSTALLATION INSTRUCTIONS

Flush fitting

The oven can be installed under a work top or in a cooking column. Figure shows the installation dimensions. Make sure that surrounding materials are heat resistant. Align the oven centrally with respect to the side walls of the units surrounding it and fix it in place with the screws and Allen screws provided.

See the accompanying instructions for combining the oven with multi-functional gas or gas-electric cookers.

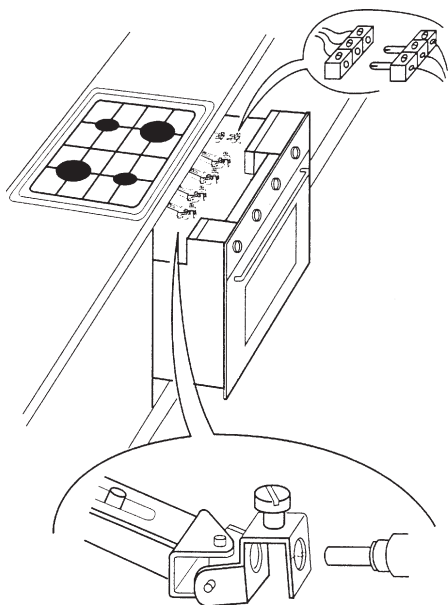
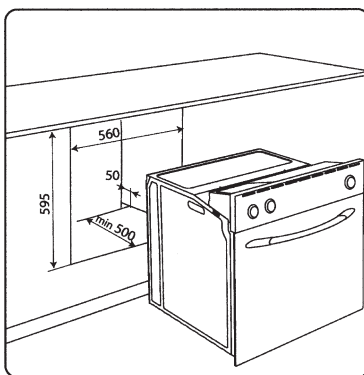
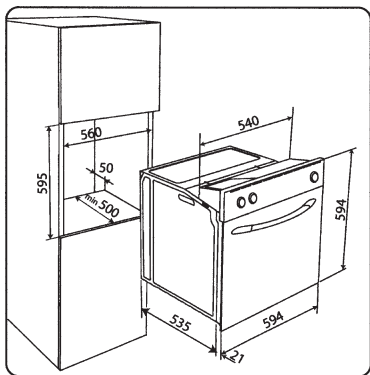

GAS OR ELECTRICAL CONNECTIONS

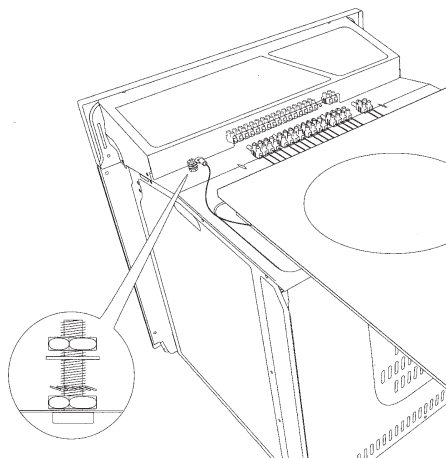

ELECTRICAL CONNECTIONS

Before connecting the oven to the mains power supply, make sure that:

- The supply voltage corresponds to the specifications on the data plate on the front of the oven.
- The mains supply has an efficient earth (ground) connection complying with all applicable laws and regulations. Correct earthing (grounding) is a legal requirement. If the appliance is not pre-fitted with a power cable and/or plug, use only suitable cables and plugs capable of handling the power specified on the appliance's data plate and capable of resisting heat. The power cable should never reach a temperature 50° C above ambient temperature at any point along its length. If the appliance is to be connected directly to mains terminals, fit a switch with minimum aperture of 3 mm between the contacts. make sure that the switch is of sufficient capacity for the power specified on the appliance's data plate, and compliant with applicable regulations. The switch must not break the yellow-green earth wire. The socket or switch must be easily reachable with the oven fully installed.

*** CABLE TYPES AND DIAMETERS**

230V~ H05RRF 3 x 1,5 mm²

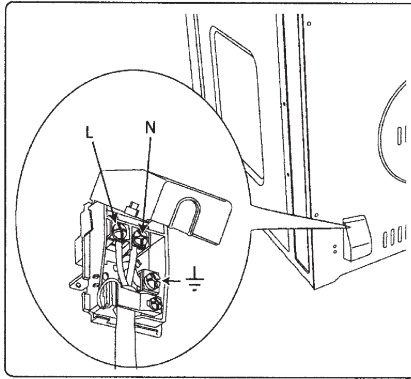

*** H05RN-F**

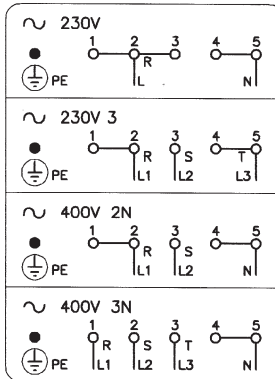
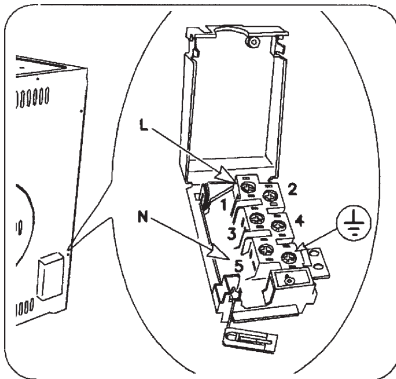

230V~

***3 x 4 mm²**

230V 3

***4 x 2,5 mm²**

400V 2N~

***4 x 2,5 mm²**

400V 3N~

***5 x 1,5 mm²**

N.B. The manufacturer declines all responsibility for damage or injury if the above instructions and normal safety precautions are not respected.

The manufacturer declines all responsibility for possible inaccuracies contained in this pamphlet, due to printing or copying errors. We reserve the right to make on our own products those changes to be considered necessary or useful, without jeopardizing the essential characteristics.

COD. 2.000.35.0